

TO DOWNLOAD THE SHEETS OF OUR PRODUCTS, REFER TO OUR WEBSITE IN THE CATALOGUE SECTION

IVFL SERIES PNEUMATIC VALVES

FAMILY 01: ON/OFF VALVES – GROUP 12, 30

IVFL pneumatic on/off valves are angle-seat valves with CF8M steel body, butt-weld or flanged connections and a servo control made of 304 stainless steel. The seal on the valve seat is of soft type, and can be made of different materials according to the customer's needs. Tightness on the stem is guaranteed by packing glands made of PTFE + graphite-loaded PTFE.



TECHNICAL DATA

Valve type	2-way ball valve, with oblique angle body, unidirectional (under shutter flow).				
Ø Servo Control	32	70	80	125	160
DN	8 (1/4") ÷ 11 (3/8")	15 (1/2") ÷ 25 (1")	25 (1") ÷ 50 (2")	40 (1 1/2") ÷ 100 (4")	80 (3") ÷ 150 (6")
Max. allowed P	40 bar (DN 8÷11); 16 bar (DN 15÷50); 10 bar (DN 65÷100); 6 bar (DN 125÷150).				
Min. allowed P	0 bar				
Connections	Butt welding; flanged; (MM GAS on demand)				
Seal	PTFE	EPDM, PTFE-coated EPDM, PTFE			
Max temperature			+150 °C with EPDM seal		
			+155° with PTFE-coated EPDM seal		
	+150 °C	+200 °C with PTFE seal			
Min. temperature	-10°C (in liquid phase)				
Air couplings	RILSAN quick coupling Ø 6-4 mm.				
Feeding fluid	instrument air				
Feeding pressure	6 – 8 bar				
Optional	inductive or magnetic sensors; pneumatic or electromechanical limit switches; stroke limit switches; solenoid valves				
MATERIALS					
Body material	CF8M				
Middle section	CF8M	CF8 + S31600 + S30400			
Stem	S31600				
Shutter plate	S31600				
Seat seal	PTFE	EPDM, PTFE-coated EPDM, PTFE			
Stem seal	PTFE+GRAPHITE-LOADED PTFE				
Body gaskets	PTFE (DN 8#11) / NOVATEC or GRAPHITE+KEVLAR (DN 15#150)				
Servo Control	S30400				

Air consumption table

CONTROL PRESSURE	AIR CONSUMPTION OF IVFL SERIES VALVES [NI / cycle]				
	Servo control Ø 32	Servo control Ø 70	Servo control Ø 80	Servo control Ø 125	Servo control Ø 160
6 bar	0.087	0.824	1.182	4.982	12.667

Table Δp of sealing (bar) for N.C. valves – without air supply.

Ø Servo c.	DN 8	DN 11	DN 15	DN 20	DN 25	DN 32	DN 40	DN 50	DN 65	DN 80	DN 100	DN 125	DN 150
32	20	12											
70	reduced		5	5	3.5								
	standard		16	14	9.5								
80	reduced					3.2	2.3	1.5					
	standard				16	14	10	6.5					
125	reduced								3	2.5	1.6		
	standard						16	14	9.5	6.5	3		
160	reduced											1.1	0.75
	standard									7.5	4.5	3.5	2.5
	enhanced								10	6	5.5	3.7	

IVFL valve dimensions - Ø 32 servo control

DN	8 1/4"	11 3/8"
A	105	105
B	149,5	149,5
Ø D	13,7	17,2
H	122	122
Kv [m³/h]	1,4	3,3

Dimensions are in mm

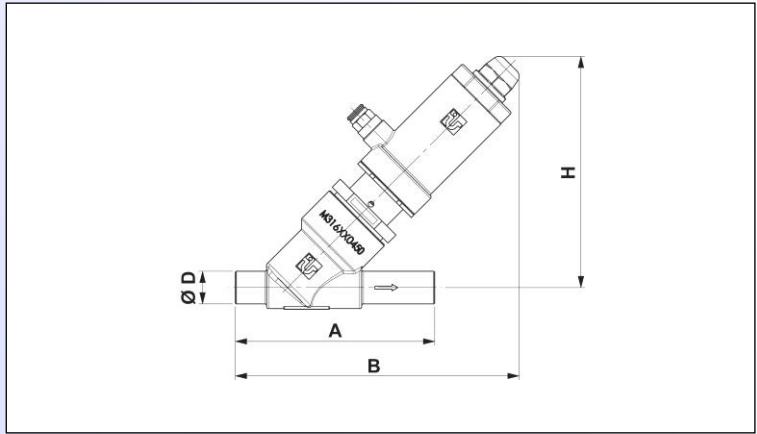

IVFL valve dimensions - Ø 70 and Ø 80 servo control

DN	15 1/2"	20 3/4"	25 1"	32 1"1/4"	40 1"1/2"	50 2"
Ø SERV.	70	70	70	80	80	80
A	146	146	156	176	196	226
B	220,5	214	204,5	220	238	284,5
Ø D	21,3	26,9	33,7	42,4	48,3	60,3
E	150	150	160	180	200	230
F	222,5	216	206,5	222	240	286,5
H	210	210,5	205	223,5	235,5	264,5
Kv [m³/h]	4,9	6	14,9	24	34,5	45,8

Dimensions are in mm

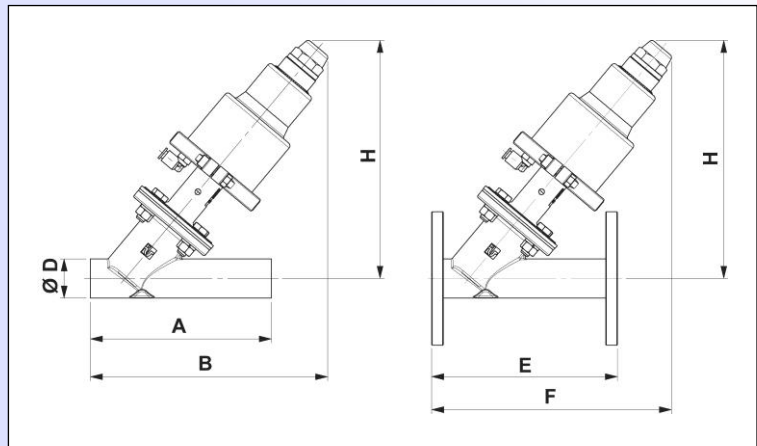

IVFL valve dimensions - Ø 125 servo control

DN	40 1"1/2"	50 2"	65 2"1/2"	80 3"	100 4"
A	196	226	290	310	345
B	307	336	384	396	440,5
Ø D	48,3	60,3	76,1	89	114,3
E	200	230	290	310	350
F	323	342	384	396	443
H	311	332,5	327	351,5	372
I	322,5	332,5			
Kv [m³/h]	41,4	51,1	90	130,5	206,5

Dimensions are in mm

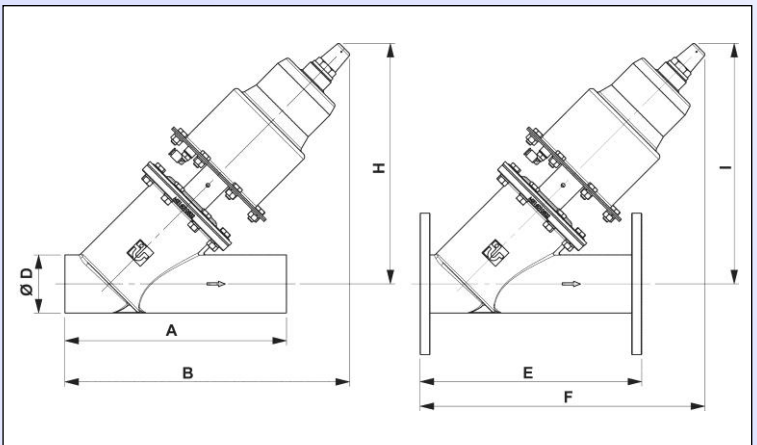

IVFL valve dimensions - Ø 160 servo control

DN	80 3"	100 4"	125 5"	150 6"
A	310	345	394	476
B	430	472	485	609,5
Ø D	89	114,3	139,7	168,3
E	310	350	400	480
F	430	474,5	488	611,5
H	384	398,5	438	422
Kv [m³/h]	153	240	372,5	417

Dimensions are in mm

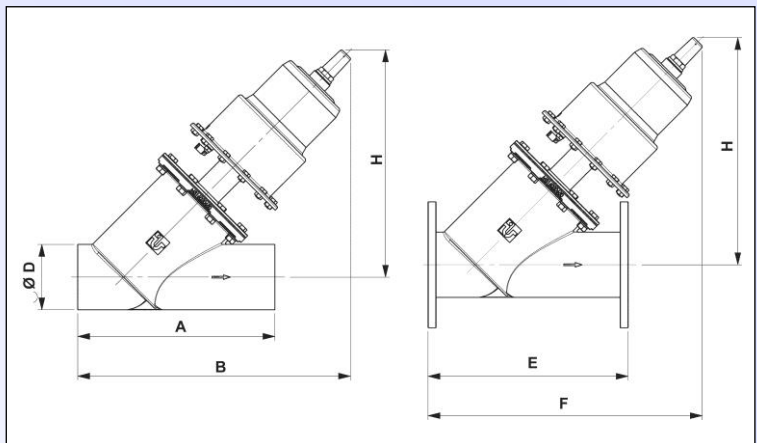

Table of Ø 32 servo control IVFL components

REF	DESCRIPTION
1	Stroke indicator
2	Servo control spring
3	Self- locking nut
4	Spring washer
5	NADUOP piston
6	Or gasket
7	Piston bearing washer
8	Air inlet fitting
9	Or gasket
10	Packing gland
11	Packing gland spring
12	Body gasket
13	Shaft with shutter
14	Transparent cap
15	Spring housing cylinder
16	Seeger ring
17	Distance ring washer
18	Intermediate body
19	Valve body

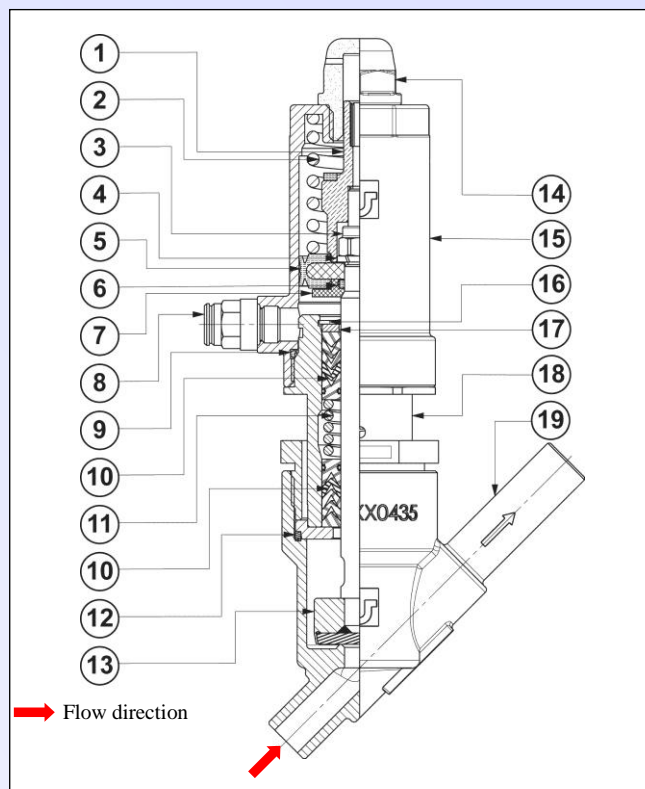

Table of Ø 70-80 servo control IVFL components

REF	DESCRIPTION
1	Stroke indicator
2	Servo control spring
3	Piston
4	DE gasket
5	Piston bearing washer
6	Or gasket
7	Clamp
8	Packing gland
9	Air inlet fitting
10	Packing gland spring
11	Body gasket
12	Shaft
13	Or gasket
14	Plug holder with plug
15	Safety washer
16	Hexagon nut
17	Transparent cap
18	Spring housing cylinder
19	Self- locking nut
20	Flat washer
21	Or gasket
22	Seeger ring
23	Distance ring washer
24	Hexagon nut
25	Intermediate body
26	Hexagon head screw
27	Spring washer
28	Hexagon nut
29	Valve body
30	Cylinder head screw

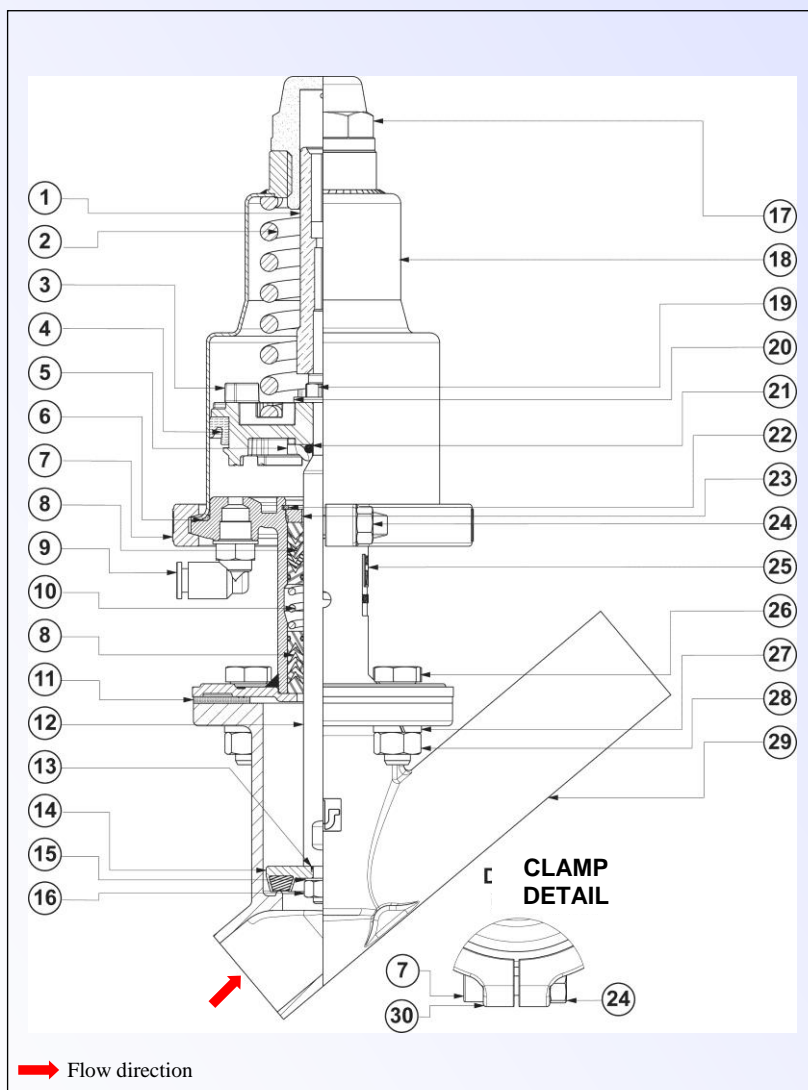

Table of Ø 125 servo control IVFL components

REF	DESCRIPTION
1	Stroke indicator
2	Servo control spring
3	TDUOP piston
4	Or gasket
5	Piston bearing washer
6	Or gasket
7	Packing gland
8	Air inlet fitting
9	Packing gland spring
10	Body gasket
11	Shaft
12	Or gasket
13	Cap holder
14	Cap
15	Cap stop washer
16	Hexagon nut
17	Transparent cap
18	Spring housing cylinder
19	Self- locking nut
20	Flat washer
21	Seeger ring
22	Distance ring washer
23	Hexagon head screw
24	Spring washer
25	Hexagon nut
26	Intermediate body
27	Hexagon head screw
28	Spring washer
29	Hexagon nut
30	Valve body

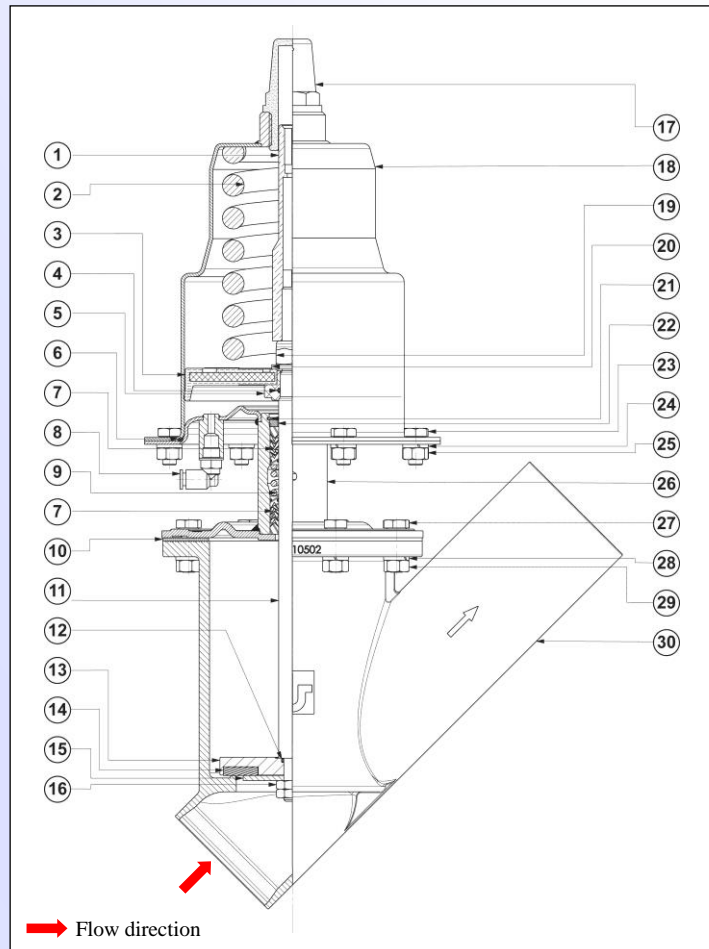

Table of Ø 160 servo control IVFL components

REF	DESCRIPTION
1	Stroke indicator
2	Servo control spring
3	Self- locking nut
4	Spring-holding plate
5	TDUOP piston
6	Piston bearing washer
7	Or gasket
8	Spring washer
9	Packing gland
10	Air inlet fitting
11	Packing gland spring
12	Body gasket
13	Shaft with plug holder
14	Cap
15	Cap stop washer
16	Hexagon nut
17	Transparent cap
18	Spring housing cylinder
19	Seeger ring
20	Distance ring washer
21	Hexagon head screw
22	Hexagon nut
23	Intermediate body
24	Hexagon head screw
25	Spring washer
26	Hexagon nut
27	Valve body

